



# RMWL-400

UNDERGROUND WHEEL LOADER





# Built for heavy loading, engineered for precision

This Rhino RMWL-400 Underground Wheel Loader is engineered with advanced features that maximize productivity, increase uptime, and reduce operating costs in demanding mining environments. A high-performance hydraulic system, optimized load-sensing technology, and operator-focused controls deliver faster cycle times and exceptional material handling efficiency.



1. Level climate-control system with automotive-style adjustable louvers helps keep the glass clear and the cab comfortable.
2. Advanced LCD monitor provides intuitive access to a wealth of operational and drilling data and functions.
3. Ergonomically correct short-throw pilot levers provide smooth, predictable fingertip control with less movement or effort.

## ENGINE & ELECTRICAL SYSTEM

Engine model	RHINO inline 6-cylinder diesel engine
Engine displacement L (cc <sup>3</sup> )	7.7 (7,700)
Diesel engine – Rated power kW @ rpm	235(315.14) @ 2,200 rpm
Diesel engine – Rated torque N·m @ rpm	1,310 @ 1,450 rpm
Emission standard	Stage III
Propulsion type	Diesel
Electrical system	24V – V/A alternator; 2×12V Ah batteries; 11 LED work lights; oil level, high temperature, low pressure indicators; reversing alarm; integrated diagnostic controller; dual horn and buzzer

## CAPACITIES AND PERFORMANCE

Rated capacity (payload) kg (lb)	9,500 (20,944)
Standard bucket capacity m <sup>3</sup> (yd <sup>3</sup> )	4 (5.23)
Ejector bucket (optional) m <sup>3</sup> (yd <sup>3</sup> )	5.8 m <sup>3</sup> (7.6 yd <sup>3</sup> )
Breakout force kN (lbf)	188.3 (42,332)
Maximum tractive effort kN (lbf)	240 (53,954)
Straight ahead static tipping load kg (lb)	25,905 (57,110)
Hydraulic cycle time (s)	11.2 s (Raise 7.6 / Dump 1.6 / Lower 2.0)
Gradeability	Approx. 15–27°

## TRANSMISSION, AXLES & WHEELS

Transmission	Dana electronic powershift – 4 forward / 4 reverse gears; integrated electronic control in steering joystick
Torque converter	Dana C (torque converter, no lock-up clutch) – Dana electronic powershift transmission 4F/4R
Front and rear axles	Kessler Model D; rigid front SAHR axle with standard differential; rear SAHR axle with ±8° oscillation
Front differential	Standard Kessler Model D differential; rear axle with limited-slip (LSD) differential
Drivetrain / Traction	4×4 (four-wheel drive)
Tires (specification and ply rating)	17.5×25 (or 18.00×25), L-5 Code, 20–24 PR (High rock resistance)

## TRAVEL SPEEDS (TRAMMING)

Max. speed – 1st gear km/h (mph)	5 (3.1)
Max. speed – 4th gear km/h (mph)	25 (15.5)
Ramp speed 15–20% km/h (mph)	4.5–6.0 (2.8–3.7)

## HYDRAULIC SYSTEM

System pressure	Work system: 210–250 bar; steering system: approx. 175–210 bar
Bucket/lift pump flow L/min (gpm)	Approx. 220 (58.1)
Reservoir capacity L (gal)	125 (33.0)
Hydraulic control	Fully hydraulic center articulation steering; combined-flow (confluence) work and steering system
Return line filtration	Return filter + high-pressure filter, oil temperature/level indicator, low-level alarm

## BRAKES & SAFETY

Brake system	Spring-applied (SAHR), fully sealed, multi-disc oil-bath brakes; service, parking and emergency brakes integrated
Braking features	Complies with EN ISO, AS and SABS standards; manual emergency brake release pump; gear-type brake pump
Automatic brake test	Automatic Brake Application (ABA) available; residual brake warning standard on CMPD
Traction control	4×4 traction with limited-slip differential on rear axle
Fire suppression	Dry-powder extinguisher; automatic suppression system (optional)
Lighting	LED lights as standard

## CABIN & ERGONOMICS

Cabin certification	ROPS / FOPS (ISO)
Air conditioning	Optional A/C in enclosed ROPS/FOPS cab
Noise level	78–82 dB(A)
Operator seat	Grammer seat with pneumatic suspension; color display (engine info and alarms)
Door interlock	Yes: applies brakes and locks steering and bucket/boom movement when door is opened
Visibility cameras	Color reversing camera available as option



Equipment specifications and images may change without notice from Rhino Equipment®

## AUTOMATION & ELECTRONICS

Control system	Multi-purpose CMPD display; front/rear brake gauges, transmission pressure, system diagnostics, residual brake warning
Load control	On-board payload weighing system available as option on all models in the segment
Auto-dig (automatic filling)	Command for Underground function (including AutoDig) optional
Tele-remote / Autonomous	Radio remote control (RRC) optional
Monitoring / Telemetry	Market-standard telemetry/fleet management available as option
Electronic diagnostics	Standard diagnostic connector; integrated CEMS diagnostic system on CMPD display

## FLUIDS & RANGE

Fuel tank L (gal)	380 (100.4)
Secondary fuel tank L (gal)	330 (87.2) option
Relative consumption	25–30 L/h at rated load operation

## STEERING & TURNING

Steering structure	Center articulation with oscillating link on slewing ring bearing
Articulation angle °	42.5°
External turning radius mm (ft)	6,550 (21.49)
Internal turning radius mm (ft)	3,250 (10.66)
Minimum working area m × m	4 × 4

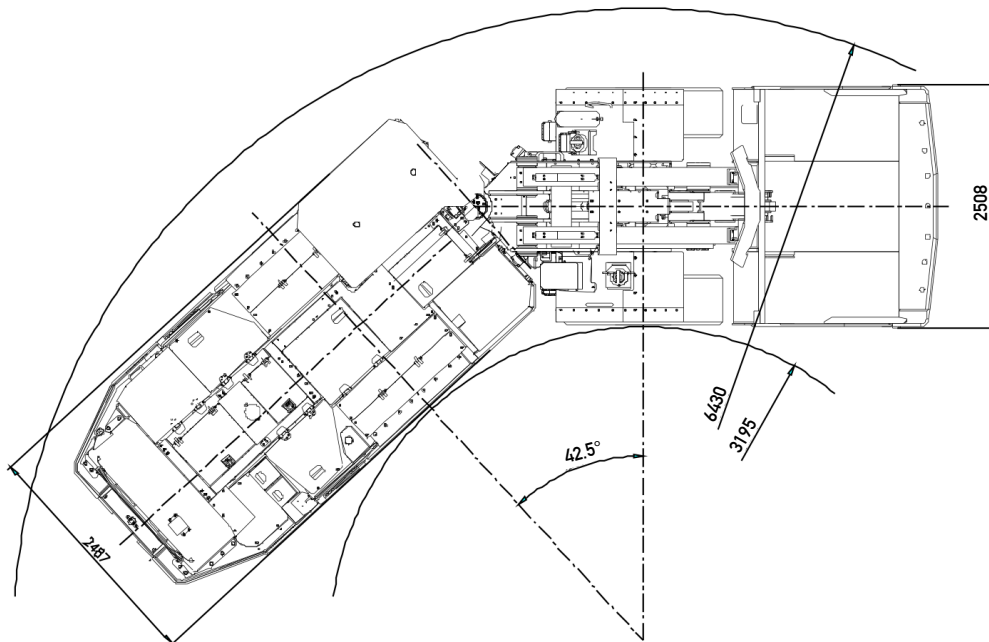

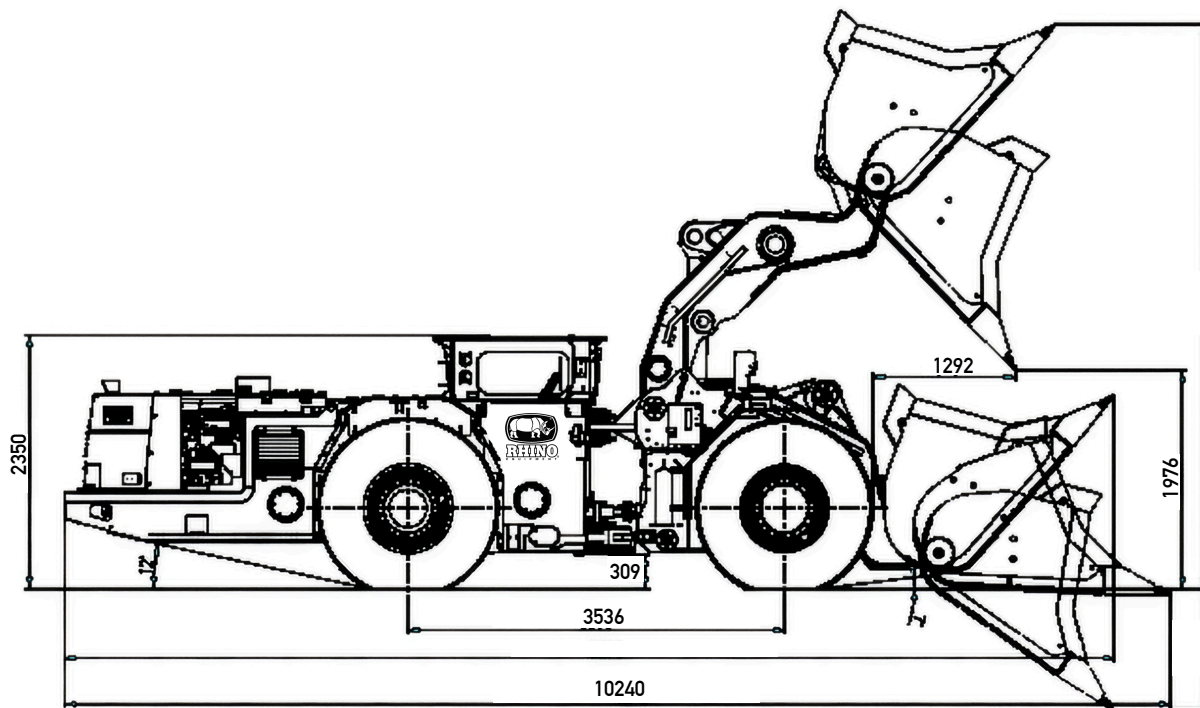

## DIMENSIONS & WEIGHTS

Empty operating weight kg (lb)	28,500 (62,832)
Total loaded weight kg (lb)	38,500 (84,878)
Overall length mm (ft)	10,277 (33.72)
Overall width mm (ft)	2,550 (8.37)
Overall height (ROPS) mm (ft)	2,380 (7.81)
Wheelbase mm (ft)	3,536 (11.60)
Ground clearance mm (in)	344 (13.5)
Dump height (Max. dumping height) mm (ft)	2,018 (6.62)
Maximum dump reach mm (ft)	1,319 (4.33)

## MAINTAINABILITY

Service point access	All daily maintenance can be performed from ground level; key components are easily accessible
Centralized lubrication	Yes (centralized lubrication system)
Oil change interval h	Engine every 500 h; transmission/hydraulics every 1,000–2,000 h; axle oil every 2,000–4,000 h
Emergency start	Standard 24V auxiliary start receptacle group (booster). Standard 24V electric starter motor

Equipment specifications and images may change without notice from Rhino Equipment®