



RMWL-305

UNDERGROUND WHEEL LOADER





Built for heavy loading, engineered for precision

This Rhino RMWL-305 Underground Wheel Loader is engineered with advanced features that maximize productivity, increase uptime, and reduce operating costs in demanding mining environments. A high-performance hydraulic system, optimized load-sensing technology, and operator-focused controls deliver faster cycle times and exceptional material handling efficiency.



1. Level climate-control system with automotive-style adjustable louvers helps keep the glass clear and the cab comfortable.
2. Advanced LCD monitor provides intuitive access to a wealth of operational and drilling data and functions.
3. Ergonomically correct short-throw pilot levers provide smooth, predictable fingertip control with less movement or effort.

POWERTRAIN & ELECTRICAL SYSTEM

| | |
|---|--|
| Engine model | RHINO RMWL 179T / Volvo TAD 850VE |
| Engine displacement L (cc ³) | 7.7 (7,700) |
| Diesel engine – Rated power kW @ rpm (HP) | 179 @ 2,200 (239.9) / 160 @ 2,200 (214.5) |
| Diesel engine – Rated torque N·m @ rpm | ~1,186 @ 1,000–1,400 / 1,060 @ 1,000–1,400 |
| Emission standard | Stage III |
| Propulsion type | Diesel |
| Electrical system | 24V – V/A alternator; 2×V/Ah batteries; V/kW starter motor; LED work lights; oil pressure/temperature/level alarms; integrated diagnostic controller and alarm; dual horn and buzzer |

PERFORMANCE & CAPABILITIES

| | |
|---|---|
| Rated capacity (payload) kg (lb) | 7,000 (15,432) |
| Standard bucket capacity m ³ (yd ³) | 3.5 (4.58) |
| Ejector bucket (optional) m ³ (yd ³) | 3.3 (4.3) |
| Breakout force kN (lbf) | 175.9 (39,524) |
| Maximum tractive effort kN (lbf) | 160–200 (35,970–44,963) |
| Straight ahead static tipping load kg (lb) | 24,000 (52,911) |
| Hydraulic cycle time (s) | 11.2 s (Raise 7.6 / Dump 1.6 / Lower 2.0) |
| Gradeability | ~ 15–27° |

TRANSMISSION, AXLES & WHEELS

| | |
|--------------------------------------|---|
| Transmission | Dana electronic powershift – 4 forward / 4 reverse gears; integrated electronic control in steering joystick |
| Torque converter | Dana C (torque converter, no lock-up clutch) – Dana powershift transmission |
| Front and rear axles | Kessler brand (Germany); rigid front axle with hydraulically released spring brake and standard differential; rear SAHR axle with oscillating frame |
| Front differential | Standard Kessler differential (Germany) |
| Drivetrain / Traction | 4×4 (four-wheel drive) |
| Tires (specification and ply rating) | 17.5×25 (or 18.00×25), L-5 Code, 20–22 PR (High rock resistance) |

TRAVEL SPEEDS (TRAMMING)

| | |
|----------------------------------|---|
| Max. speed – 1st gear km/h (mph) | 4 (2.5) |
| Max. speed – 4th gear km/h (mph) | 21 (13.0) |
| Ramp speed 15–20% km/h (mph) | On 15% grade, 1st gear loaded ~4.5 km/h; 2nd gear ~8–9 km/h |

HYDRAULIC SYSTEM

| | |
|-----------------------------------|--|
| System pressure | Steering: fixed-displacement gear pump; work: fixed-displacement gear pump |
| Bucket/lift pump flow L/min (gpm) | 150–200 (40–53) |
| Reservoir capacity L (gal) | 88–125 (23–33) |
| Hydraulic control | Fully hydraulic center articulation steering with two double-acting cylinders, hydraulic pilot control; inverted 6-bar linkage work system |
| Return line filtration | Return filter + high-pressure filter, oil temperature/level indicator, low-level alarm |

BRAKES & SAFETY

| | |
|----------------------|---|
| Brake system | Spring-applied (SAHR), fully sealed, multi-disc oil-bath brakes; service, parking and emergency brakes integrated |
| Braking features | Combined service, parking and emergency braking in a single system |
| Automatic brake test | Automatic Brake Application (ABA) and residual brake warning available as option |
| Traction control | 4×4 traction |
| Fire suppression | Dry-powder extinguisher + optional automatic system, standard fire bulkhead and catalytic exhaust purifier |
| Lighting | LED lights as standard |

FLUIDS & RANGE

| | |
|-----------------------------|-----------------------------------|
| Fuel tank L (gal) | 280 (74.0) |
| Secondary fuel tank L (gal) | 330 (87.2) option |
| Relative consumption | 15–22 L/h at rated load operation |



CABIN & ERGONOMICS

| | |
|---------------------|---|
| Cabin certification | ROPS / FOPS (ISO) |
| Air conditioning | Enclosed cab with A/C (standard), A/C installed independently from the cab |
| Noise level | 78–82 dB(A) |
| Operator seat | Murphy color display |
| Door interlock | Yes: applies brakes and locks steering and bucket/boom movement when door is opened |
| Visibility cameras | Reversing camera available as option; reversing alarm as standard |

AUTOMATION & ELECTRONICS

| | |
|------------------------------|---|
| Control system | CMPD display with speedometer/tachometer, fuel level, hydraulic oil/coolant/transmission temperature, brake pressure, diagnostics |
| Load control | Hydraulic pressure-based on-board payload weighing system available as option |
| Auto-dig (automatic filling) | Auto-dig available as option |
| Tele-remote / Autonomous | Radio remote control (RRC) optional |
| Monitoring / Telemetry | Telemetry/fleet management systems available as option |
| Electronic diagnostics | Standard diagnostic connector; CEMS system with integrated system diagnostics. Standard electronic diagnostics |

STEERING & TURNING

| | |
|---------------------------------|---|
| Steering structure | Center articulation with oscillating link on slewing ring bearing |
| Articulation angle ° | 42.5° |
| External turning radius mm (ft) | 6,712 (22.02) |
| Internal turning radius mm (ft) | 3,087 (10.13) |
| Minimum working area m × m | 3.8 × 3.8 |

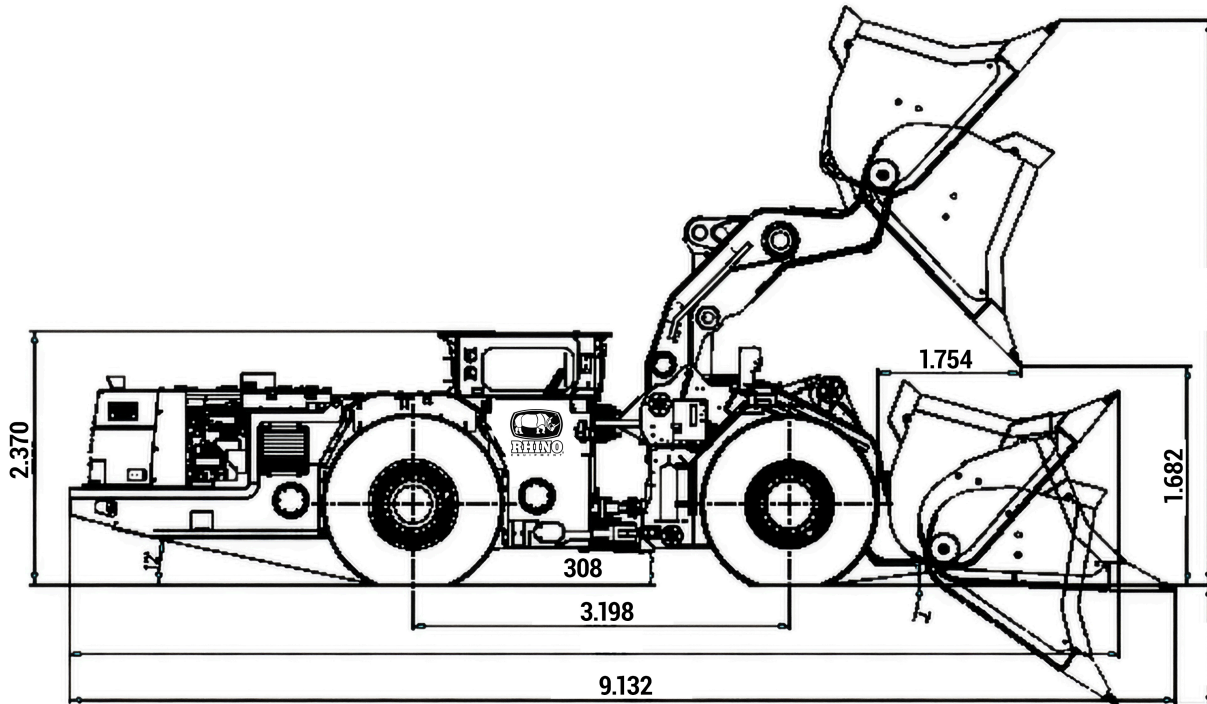
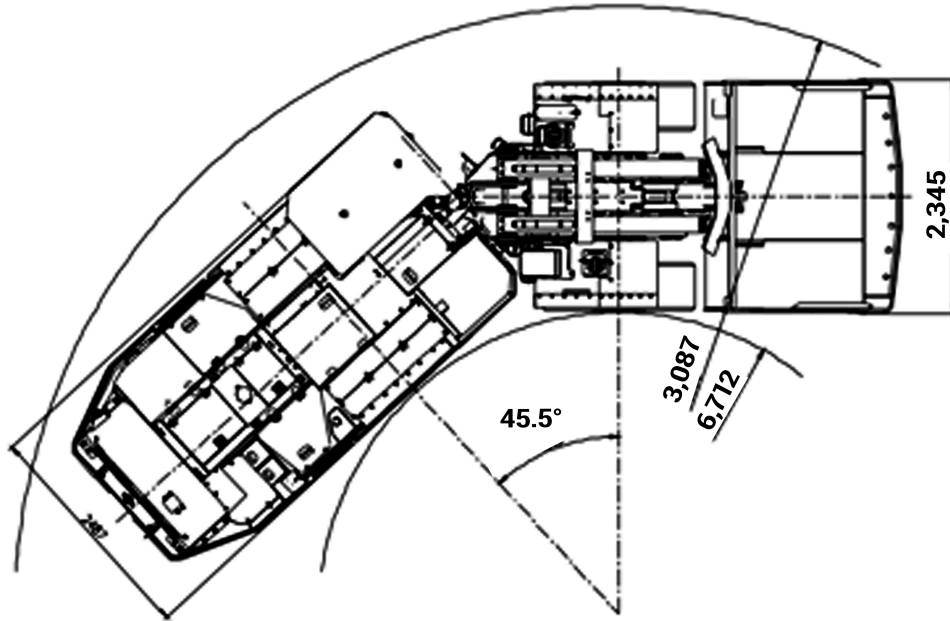

Equipment specifications and images may change without notice from Rhino Equipment®

DIMENSIONS & WEIGHTS

| | |
|--|-----------------|
| Empty operating weight kg (lb) | 19,250 (42,439) |
| Total loaded weight kg (lb) | 26,250 (57,871) |
| Overall length mm (ft) | 9,132 (29.96) |
| Overall width mm (ft) | 2,345 (7.69) |
| Overall height (ROPS) mm (ft) | 2,370 (7.78) |
| Wheelbase mm (ft) | 3,198 (10.49) |
| Ground clearance mm (in) | 308 (12.13) |
| Dump height (Max. dumping height) mm (ft) | 1,682 (5.52) |
| Maximum dump reach mm (ft) | 1,754 (5.75) |

MAINTAINABILITY

| | |
|-------------------------|--|
| Service point access | All daily maintenance can be performed from ground level; key components are easily accessible |
| Centralized lubrication | Semi-centralized lubrication as standard; centralized or automatic as option |
| Oil change interval h | Engine every 250–500 h; Dana transmission every 1,000–2,000 h; hydraulics every 2,000 h |
| Emergency start | Standard 24V auxiliary start receptacle group. Standard 24V auxiliary start |