



RMWL-103

UNDERGROUND WHEEL LOADER





Built for heavy loading, engineered for precision

This Rhino RMWL-103 Underground Wheel Loader is engineered with advanced features that maximize productivity, increase uptime, and reduce operating costs in demanding mining environments. A high-performance hydraulic system, optimized load-sensing technology, and operator-focused controls deliver faster cycle times and exceptional material handling efficiency.



1. Level climate-control system with automotive-style adjustable louvers helps keep the glass clear and the cab comfortable.
2. Advanced LCD monitor provides intuitive access to a wealth of operational and drilling data and functions.
3. Ergonomically correct short-throw pilot levers provide smooth, predictable fingertip control with less movement or effort.

ENGINE & ELECTRICAL SYSTEM

Engine model	RHINO RMWL 92.5T / Volvo TAD 850VE
Engine displacement L (cc ³)	4.5 (4,500)
Diesel engine – Rated power kW (HP) @ rpm	92.5 (124) @ 2200 / 74 (99) @ 2200
Diesel engine – Rated torque N·m @ rpm	551 @ 1300 / 440 @ 1300
Emissions standard	Stage III
Propulsion type	Diesel
Electrical system	24V – alternator, starter batteries, LED lights (standard); reverse alarm; work light system

CAPACITIES AND PERFORMANCE

Rated payload kg (lb)	2,000 (4,409)
Standard bucket capacity m ³ (yd ³)	1 (1.31)
Ejector bucket (option) m ³ (yd ³)	0.8 (1.04)
Breakout force kN (lbf)	117.9 (26,504)
Maximum tractive force kN (lbf)	60–100 (13,489–22,481)
Static tipping load, straight kg (lb)	20,575 (45,360)
Hydraulic cycle time (s)	9.3 s (Raise 5.0 / Dump 2.0 / Lower 2.3)
Gradeability	15°–18° (27–32%)

TRANSMISSION, AXLES & WHEELS

Transmission	Hydrostatic CVT (variable displacement pump and motor)
Torque converter	Hydrostatic drive – no conventional torque converter
Front and rear axles	Compact Dana/Kessler-type axles; rigid front axle, rear axle with ±8°–10° oscillation
Front differential	Standard (open) front and rear differential; rear oscillation ±8°–10°
Drive	4x4 (four-wheel drive)
Tires (spec and ply rating)	L-4S (o L-5S), 14 PR a 16 PR (High rock resistance)

TRAVEL SPEEDS (TRAMMING)

Max. speed – 1st gear km/h (mph)	8 (5.0)
Max. speed – 4th gear km/h (mph)	26.3 (16.3)
Ramp speed 15–20% grade km/h (mph)	15–20%: 3–5 (laden @ 2,200 rpm)

HYDRAULIC SYSTEM

System pressure	Working pressure 210–250 bar; steering 170–200 bar
Bucket / lift pump flow L/min (gpm)	80–120 (21–32)
Reservoir capacity L (gal)	88 (23.2)
Hydraulic control	Fully hydraulic centre-articulated steering with two double-acting cylinders; pilot hydraulic control; 6-bar inverted-linkage work system
Return-line filtration	In-line return filter + clogging indicator; typical filtration rating 10–25 µm

BRAKES & SAFETY

Brake system	Spring-applied hydraulic-release (SAHR) brakes, fully sealed, multi-disc oil-bath; service, parking and emergency brakes integrated in one system
Braking characteristics	Combined service, parking and emergency braking in a single system
Automatic brake test	Automatic Brake Application (ABA) and residual brake warning available as option
Traction control	4x4 traction
Fire suppression	Dry-powder portable extinguisher (standard); automatic suppression system available as option. Mining regulations generally require an approved automatic system
Lighting	LED lights (standard)

CABIN & ERGONOMICS

Cab certification	ROPS / FOPS (ISO)
Air conditioning	A/C available as option in enclosed cabs
Noise level	78–82 dB(A) (enclosed ROPS cab); without enclosed cab 82–90 dB(A)
Operator seat	Seat with basic mechanical or pneumatic suspension, seat belt; basic instrument display
Door interlock	Yes: applies brakes and locks steering and bucket/boom movement when door is opened
Visibility cameras	Audible reverse alarm (standard); reverse camera available as option



Equipment specifications and images may change without notice from Rhino Equipment®

AUTOMATION & ELECTRONICS

Control system	Basic panel with pressure, temperature and fuel-level gauges; visual and audible alarms
Payload control	Estimated weighing via hydraulic pressure; available as option
Autodig (auto-fill)	Not available
Tele-remote / Autonomous	Radio telecontrol available as option; autonomous operation not available in this size segment
Monitoring / Telemetry	Telemetry / fleet-management systems available as option
Electronic diagnostics	Diagnostic connector (standard); CEMS system with integrated diagnostics. Standard electronic diagnostics

FLUIDS & RANGE

Fuel tank capacity L (gal)	90 (23.8)
Secondary fuel tank L (gal)	90 (23.8) – option
Relative consumption	6–10 L/h at rated load

STEERING & TURNING

Steering structure	Centre-articulated with oscillating link on slew bearing
Articulation angle °	36°
Outer turning radius mm (ft)	4,142 (13.59)
Inner turning radius mm (ft)	2,374 (7.79)
Minimum working area m x m	2.5 x 2.5

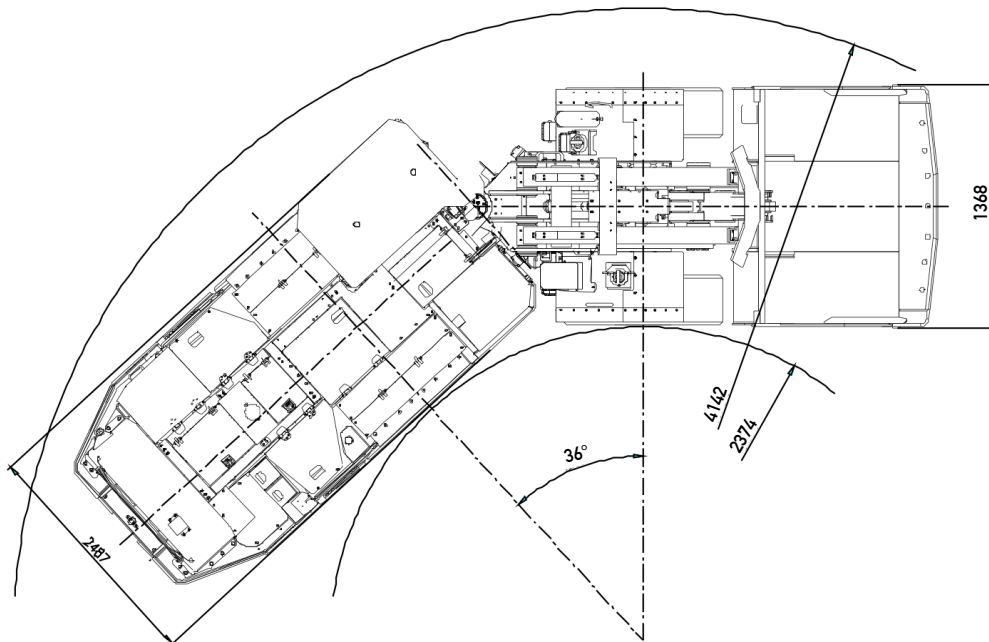

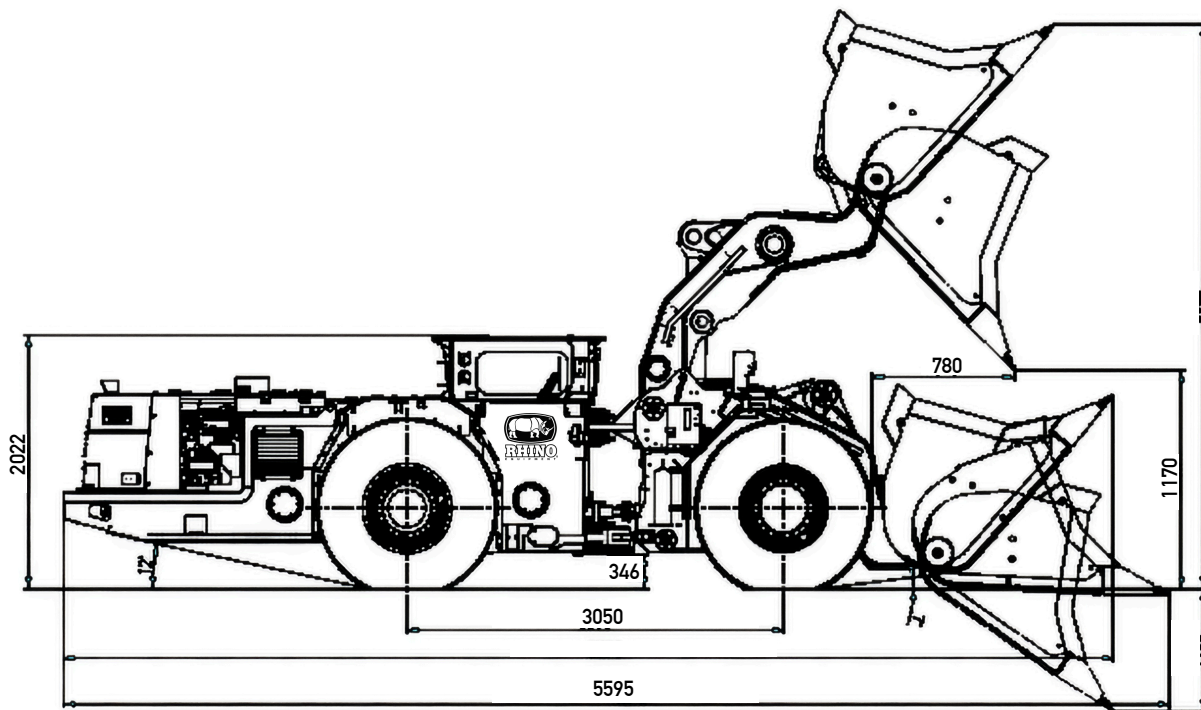

DIMENSIONS & WEIGHTS

Operating weight – empty kg (lb)	7,200 (15,873)
Gross vehicle weight – laden kg (lb)	9,200 (20,282)
Overall length mm (ft)	5,595 (18.36)
Overall width mm (ft)	1,368 (4.49)
Overall height (ROPS) mm (ft)	2,022 (6.63)
Wheelbase mm (ft)	3,050 (10.00)
Ground clearance mm (in)	346 (13.62)
Maximum dumping height mm (ft)	1,170 (3.84)
Maximum dump reach mm (ft)	780 (2.56)

MAINTAINABILITY

Service access points	All daily maintenance can be performed from ground level; key components easily accessible
Centralised lubrication	Manual lubrication
Oil change interval (h)	Engine: every 250–500 h; transmission and hydraulics: every 1,000–2,000 h
Emergency start	24V auxiliary jump-start receptacle (standard); auxiliary start plug standard across all models in segment

Equipment specifications and images may change without notice from Rhino Equipment®