



RFD2X-4590

FACE DRILL





Maximum control for precise and consistent drilling

This Rhino RFD2X-4590 face drill is loaded with enhancements that not only increase productivity and uptime, but lower daily operating costs too. A high-efficiency hydraulic system, advanced digital control interface, and specific drilling modes to allow you to choose your penetration profile headline the long list of advances.



1. Level climate-control system with automotive-style adjustable louvers helps keep the glass clear and the cab comfortable.

2. Advanced LCD monitor provides intuitive access to a wealth of operational and drilling data and functions.

3. Ergonomically correct short-throw pilot levers provide smooth, predictable fingertip control with less movement or effort.

ENGINE AND POWERTRAIN

Engine Make - Model	RHINO RFD164T / Cummins QSB5.9
Engine power kW (HP) @ rpm	164 (220) @ 2200 / 154 (206) @ 2200
Emissions certification (Tier / Stage)	Tier 3 / Stage III
Transmission (Type / Model)	Hydrodynamic / DANA
Chassis type	Heavy articulated
Steering and articulation angle (°)	Hydrostatic power steering, ±42
Axles / Brakes	DANA / SAHR
Maximum speed km/h (mph)	14 (8.7)
Maximum gradeability (%)	25 (14)
Tire dimensions and type	14.00R24
Fuel tank capacity L (gal)	160 (42.2)
Exhaust gas purification system	Catalytic purifier with muffler

HYDRAULIC SYSTEM

Hydraulic pump type	Variable displacement piston
Maximum system pressure bar (psi)	230 (3,335)
Hydraulic tank capacity L (gal)	350 (92.4)
Filtration µm	10
Oil cooling system	Water-to-oil heat exchanger

POSITIONING BOOM

Number of booms	2
Boom extension mm (ft)	1600 (5.2)
Lift angle (°)	+55 / -30
Swing angle (°)	+45 / -45
Roll-over angle (°)	360
Automatic parallelism	Hydraulic-mechanical
Anti-collision system	Integrated electronic
Boom weight kg (lb)	2500 (5511)

HYDRAULIC DRIFTER

Impact power kW (HP)	18 (24.1)
Percussion pressure bar (psi)	180 (2610)
Percussion frequency Hz (bpm)	60 (3600)
Rotation speed rpm	0 - 300
Rotation torque Nm (lb-ft)	750 (553)
Drilling diameter mm (in)	45 - 76 (1.77 - 3.0)
Shank adapter	T38 / T45
Lubrication air consumption L/s (cfm)	5 (10.6)
Anti-jamming system	Automatic hydraulic
Drifter safety systems	Double impact dampening
Total operating weight kg (lb)	35000 (77161)

FEED BEAM

Feed beam type	Aluminum profile
Feed type	Cylinder and cable/chain
Feed extension mm (ft)	1600 (5.2)
Feed force kN (lbf)	15 (3372)
Maximum rod length mm (ft)	5561 (18.24)
Hole depth mm (ft)	5214 (17.10)



Equipment specifications and images may change without notice from Rhino Equipment Group Inc.

DRILLING COVERAGE

Maximum coverage area m ² (ft ²)	115 (1237.8)
Maximum coverage (Width × Height) mm (ft)	13800 × 9700 (45.2 × 31.8)
Minimum tunnel section m (ft)	4.5 × 4.5 (14.76 x 14.76)
Maximum tunnel section m (ft)	13.8 X9.7 (45.28 × 31.83)
Inside turning radius mm (ft)	4122 (13.52)
Outside turning radius mm (ft)	7547 (24.76)

ELECTRICAL SYSTEM (OPERATION)

Main electric motor kW (HP)	110 (147.5)
Total installed power kW (HP)	122 (163.6)
Voltage / Frequency V (Hz)	380 (50)
Starting method	Star-Delta
Cable reel length m (ft)	80 (262.4)
IP protection rating	IP55
Battery electric tramming	No
Battery system	24V (2 x 12V 80Ah)

WATER AND AIR SYSTEM

Compressor type	Rotary screw
Compressor capacity m ³ /min (cfm)	0.9 (31.7)
Working air pressure bar (psi)	8 (116)
Lubrication air pressure bar (psi)	2.5 (36.2)
Water pump type	Multistage centrifugal
Water flow L/min (gpm)	150 (39.6)
Maximum water pressure bar (psi)	20 (290)
Pump motor power kW (HP)	4 (5.4)

AUTOMATION, CONTROL AND CONNECTIVITY

Control system	Direct Hydraulic Control (DHC)
Automation level	Manual / Assisted
Anti-jamming system	Hydraulic via rotation pressure
Positioning control	Manual via levers
Teleremote operation	Optional
Remote monitoring	Optional

CABIN, ERGONOMICS AND SAFETY

Structure certification (FOPS / ROPS)	FOPS / ROPS
Cabin type	Hydraulically adjustable canopy
Internal noise level in cabin dB(A)	<105
Air conditioning and HEPA filtration system	No
Fire suppression system	Manual
Centralized lubrication system	Centralized manual
Blind-spot assist cameras and LED lighting	High-intensity LED lighting

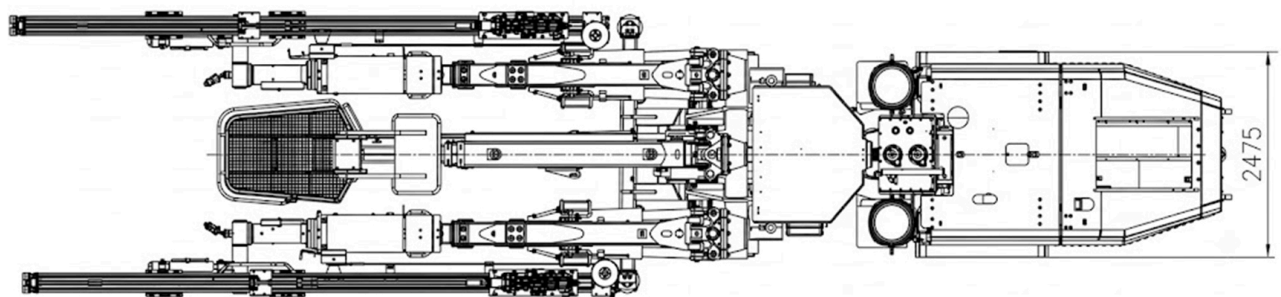
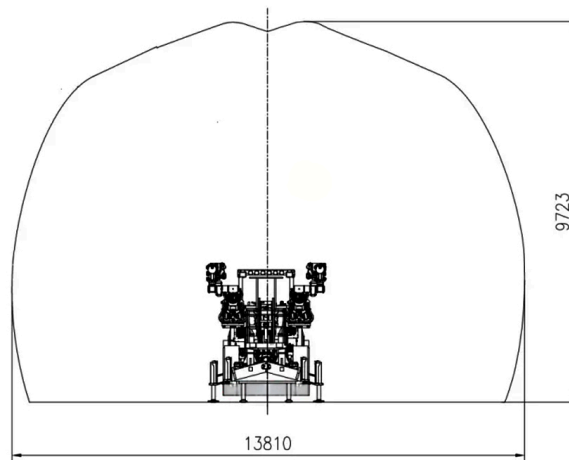

Equipment specifications and images may change without notice from Rhino Equipment Group Inc.

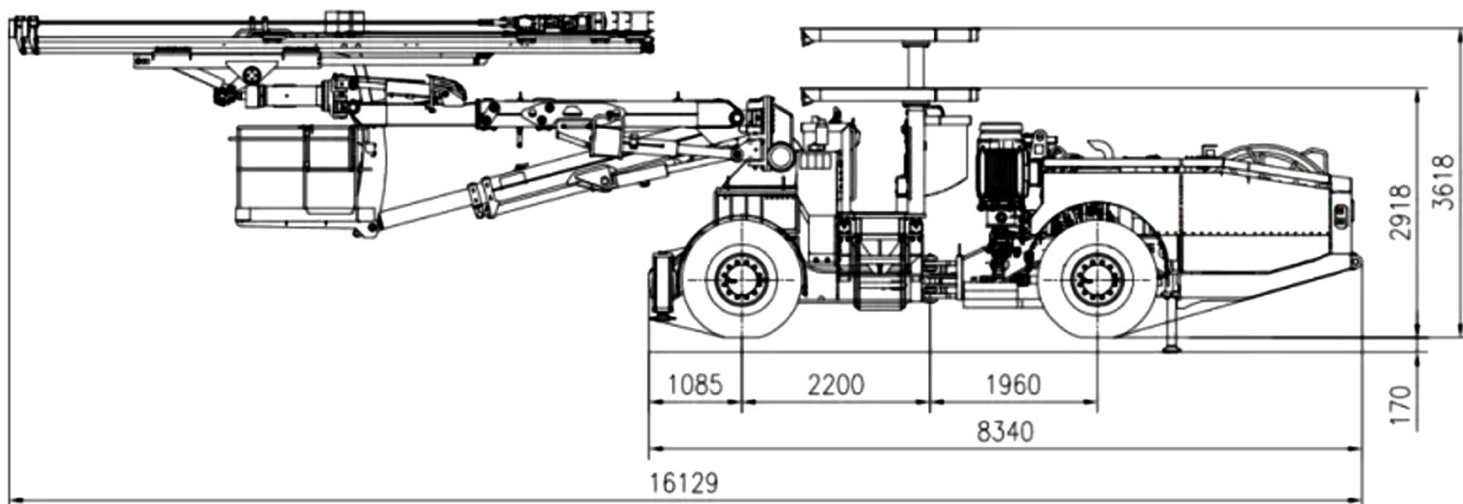

DIMENSIONS AND WEIGHT (TRAMMING POSITION)

Total length mm (ft)	16148 (52.98)
Transport width mm (ft)	2517 (8.26)
Transport height mm (ft)	2945 (9.66)
Ground clearance mm (in)	361 (14.21)
Wheelbase mm (in)	3934 (154.88)
Rear chassis length mm (in)	1983 (78.07)
Total length of hydraulic jacks mm (in)	8382 (329.99)
Vertical extension of the cabin roof mm (in)	735 (28.93)
Maximum chassis height with extended cabin mm (ft)	3637 (11.93)
Front chassis width with stabilizers mm (ft)	2501 (8.20)
Rear chassis transport height mm (in)	199 (7.83)
Approach angle (°)	15
Departure angle (°)	13