



RSC233

SOIL COMPACTORS



Integrated design for long life and uptime



Safety starts with an alert, comfortable operator. Air conditioning and filtered air keep the operator cool and on task.

Landfill compactors are essential equipment for maintaining refuse landfill sites. This compactor can push, spread, pulverize, demolish, and compact refuse effectively. Using this type of compactor helps save and protect the environment and extend the operating life of landfill sites.

The constant direction changes, poor underfoot conditions and debris riddled environment of the landfill are easily managed by the rugged and dependable Rhino Soil Compactors drive train components.

Infrared cameras and backup buzzer provide extra safety for the operator and its environment.

Different types of baldes are available to our customers for dozing or spreading to match site requirements.

ENGINE

Engine Make / Engine Model	Cummins QSM11 or Rhino®
Net Power kW (Hp) @2,200rpm	250(335.3)
Displacement L (cu. in)	11.0(671)
Emissions Rating (optional)	Tier 2 (Tier 3, Tier 4)
Fuel System	Direct Injection
Lubrication	Full-flow spin-on filter
Aspiration	Turbocharged
Air Cleaner	Under-hood, dual element dry type
Fan Drive	Belt driven
Electrical System	24 Volts with 70 Amp alternator
Drive Mode	Hydraulic transmission, power shift, all wheel drive

TRANSMISSION

Type	Electronically controlled hydrostatic motors drive each wheel for greater traction
Max. Travel Speed km/h (mph)	8.0(5.0)

HYDRAULIC SYSTEM

Pump Type	Axial piston pump, variable displacement, closed center
System Pressure Map (psi)	15(2.176)
Pump Flow L/min (gpm)	210(55.5)

AXLES

Front	Fixed
Oscillating Rear (°)	10

BRAKE SYSTEM

Service Brakes	Air-driven, four-wheel caliper disc brakes
Parking Brake	Spring Applied Hydraulic Release (SAHR) brakes

Equipment specifications and images may change without notice from Rhino Equipment Group Inc.

WHEELS

Front Drum Width mm (ft)	1,350(4.4)
Rear Drum Width mm (ft)	1,130(3.7)
Drum Diameter mm (ft)	1,620(5.3)
Blades per Wheel, Front	60
Blades per Wheel, Rear	50

BLADE

Type	Straight
Blade Width mm (ft)	4,000(13.1)
Blade Height mm (ft)	1,980(6.5)

REFILL CAPACITIES L (gal)

Fuel Tank	500(132.1)
Cooling	65(17)
Engine Oil	55(15)
Transmission	55(15)
Final Drives (each)	45(12)
Hydraulic Tank	350(92)

OPERATING WEIGHT

Machine Weight kg (lb)	33,000(72.753)
------------------------	----------------

Compactor operating information is based on machine with identified linkage and standard equipment, full fuel tank, and 79-kg (175 lb) operator. This information is affected by changes in type of drums, ballast and different attachments.

Equipment specifications and images may change without notice from Rhino Equipment Group Inc.

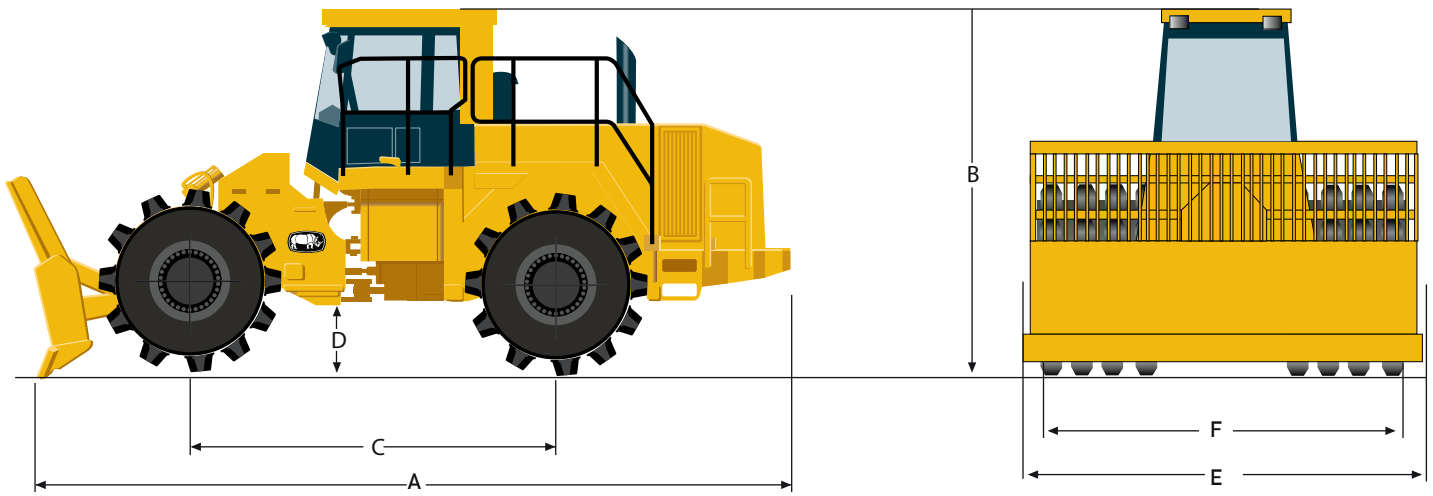

MACHINE DIMENSIONS

A - Overall Length mm (ft)	8,250(27.1)
B - Max. Machine Height mm (ft)	3,750(12.3)
C - Wheelbase mm (ft)	3,500(11.5)
D - Ground Clearance mm (ft)	610(2.0)
E - Overall Width mm (ft)	4,000(13.1)
F - Width Over Tires mm (ft)	3,630(11.9)
Articulation Angle (°)	30
Gradeability (°)	45

PERFORMANCE PARAMETERS

Max. Climbing Ability (%)	100
Steering Angle (°)	40
Lateral Swing Angle (°)	15
Turning Radius (Outside of Front) mm (ft)	7,000(23.0)

Equipment specifications and images may change without notice from Rhino Equipment Group Inc.

OPTIONS

ROPS/FOPS Cab, Infrared Outside Camera, Tilt Cylinder for Blade, A/C, U-Blade, Semi-U Blade, Soil Compaction Drums
Tier 3, Tier 4 engine.

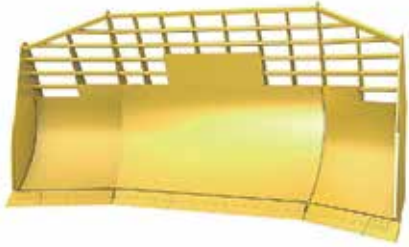

Landfill Blades

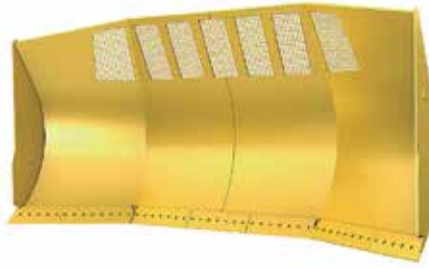

Woodchip Blades

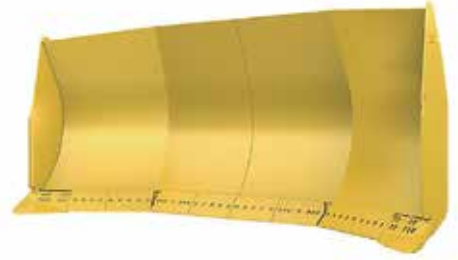

Coal U Blades

Equipment specifications and images may change without notice from Rhino Equipment Group Inc.