



RD24

BULLDOZER



Best-in-class access to service and maintenance points for maximum uptime

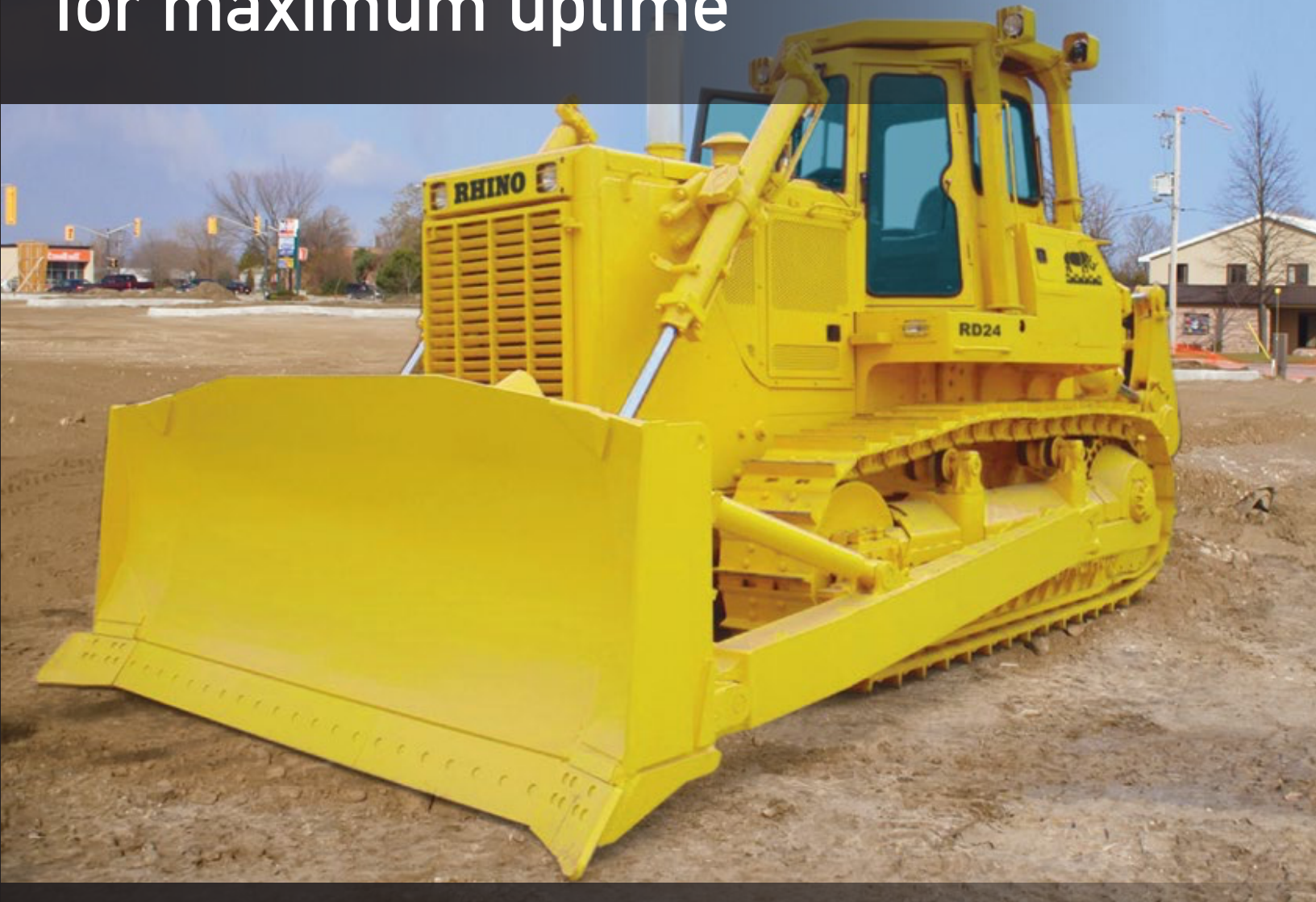

Rhino Dozers combine incredible versatility to handle a wide range of jobs with innovations that help you do those jobs better, faster and more efficiently. These crawler dozers are ideal for residential construction performing such tasks as clearing and grading lots, sloping the sides of roads, back-filling, and final grade work for landscaping and driveway construction.

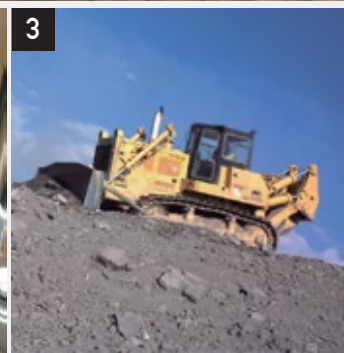

1. Standard high-back seat and lower cushion adjust multiple ways for daylong comfort and support.
2. Easy-to-read, high-visibility gauges and warning lamps keep the operator aware of critical system information.
3. Speed travel can also be varied to fit specific applications, terrain conditions, or operating preferences.

ENGINE	
Make / Engine Model	Cummins / NT855/ NTA855 or Rhino
Emission Rating	Tier 2 (Tier 3, Tier 4)
Cylinders	6
Displacement L (cu.In)	14(854)
Net Power kW (Hp) @ 1800 / @2100 r/min	175/(235) /209(280)
Net Peak Torque Nm (lb.ft) @1,300 rpm /@ 1500 rpm	1,085(800) /1139 (837)
Fuel System	Direct Injection
Aspiration	Turbocharged, charge air cooled
Air Cleaner	Under hood , dual element dry type, restriction indicator on filter housing for service
COOLING	
Fan Drive / Optional	Belt Driven / Hydraulic reversible
TRANSMISSION	
Type	Powershift, Hydrostatic, planetary gear and multiple disc clutch, hydraulically actuated; tracks are moved by a central spiral-bevel gear to provide instant power; gear selection lever with linkage mechanism; engine speed lever and decelerator pedal to control ground speed
System Pressure Mpa (psi)	2(290)
Maximum Travel Speeds	Forward Reverse
1st Gear km/h (mph)	4(2) 4(3)
2nd Gear km/h (mph)	7(4) 8(5)
3rd Gear km/h (mph)	10(6) 13(8)
Steering	Individual levers to control each track to provide precision steering; Steering clutch provides immediate response to the operator
Final Drive	Double reduction final drives mounted enclosed and isolated to protect them from shocks and debris
Drawbar Pull kN (lb)	
Maximum / Optional	270(60,698)
At 2.0 km/h (1.2 mph)	170(38,218)
At 6.0 km/h (3.7 mph)	50(11,240)
Service Brake	Dynamic braking when decelerator pedal is actuated; brake pedal actuation, hydraulically activated drums on each track for instant stop and reliability.
Parking Brake	Manually activated

HYDRAULICS

Type	Gear Pump
Pressure Mpa (psi)	14(2,031)
Max. Flow L/min (gpm)	262(69)
Control	Lever control for blade with float mode: lever control for ripper

ELECTRICAL

Battery	24 volts
Alternator Rating / Optional	50A
Lights	2 Front Lights, 2 Rear Lights

UNDERCARRIAGE

Track Gauge mm (in)	1,880(74.0)
Grouser Width mm (in) / Optional	560(22.0) / 600(23.0)
Chain	Sealed and lubricated
Shoes, Each Side	38/42
Track Rollers, Each Side	6
Track Length on Ground mm (in)	3,168(124.7)
Ground Contact Area cm ² (sq.in)	35,504(5,503)
Ground Pressure Kpa (psi)	60(8,720)/65(9,427)
Track Pitch mm (in)	216(8.5)
Operator Station	ROPS and FOPS

REFILL CAPACITIES

Fuel Tank / Optional	450(119) / 550(145)
Cooling System	118(31)
Engine Oil	20(5)
Transmission Fluid	150(40)
Hydraulic Tank	100(26)
Steering	70(18)
Final Drive Case (for both)	40(11)

OPERATING WEIGHTS

Base Weight / Optional	25,700 - 30,700 (56,658-67,682)
Weight with 3-Shank Ripper kg (lb)	29,600 - 34,600 (65,257-76,280)

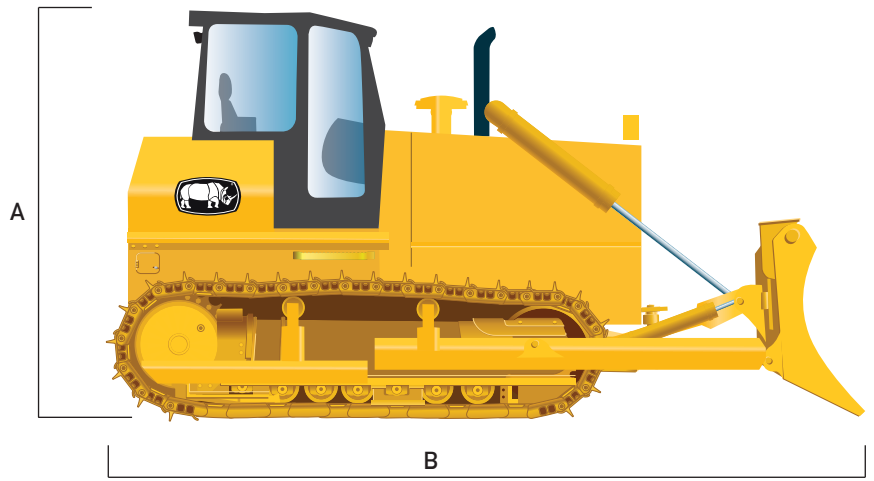
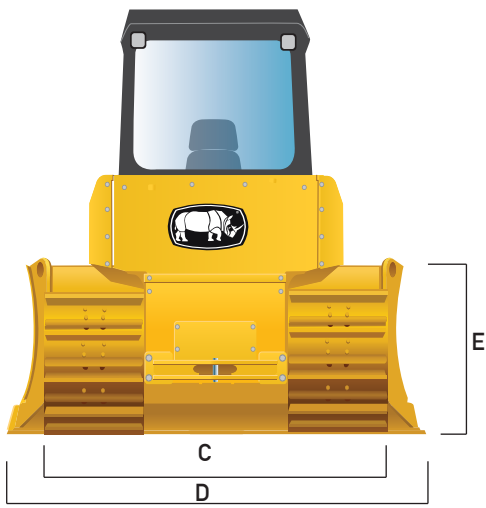

MACHINE DIMENSIONS

Blade Type	Angle	Straight-tilt
A. Height to Top of Cab mm (ft)	3,402(11.2)	3,402(11.2)
B. Overall Length mm (ft)	6,300(20.7)	6,332(20.8)
C. Width Over Track mm (ft)	2,895(9.5)	2,895(9.5)
D. Blade Width mm (ft)	4,253(14.0)	3,823(12.5)
E. Blade Height	1,100(3.6)	1,280(4.2)
Tread Depth with Single-Bar Grouser mm (in)	60(2.4)	60(2.4)
Ground Clearance in Dirt mm (in)	404(15.9)	404(15.9)
Length With Ripper mm (ft)	7,571(24.8)	7,604(24.9)
Blade Lift Height mm (in)	1,115 (43.9)	1,170(46.1)
Blade Digging Depth mm (in)	500(19.7)	670(26.4)
Blade Cutting-Edge Angle (°)	55	55
Blade Capacity m ³ (cu. Yd)	5.2(6.8)	6.3(8.2)
Blade Angle (°)	25	—
Blade Tilt mm (in)	400(15.7)	400(15.7)
Minimum Turning Radius mm (ft)	3,100(10.2)	3,100 (10.2)
Gradeability (°)	30	30

RIPPER

Single or Multi-shank (3) parallelogram ripper with hydraulic pitch adjustment and replaceable tips

Weight kg (lb)	3,900(8,598)
Max. Penetration mm (in)	600(23.6)
Max. Clearance Under Tip mm (in)	500(19.7)
Overall Length Lowered Position mm (in)	1,272(50.1)
Slope Angle (full raise) (°)	24

BLADES



Angle Blade

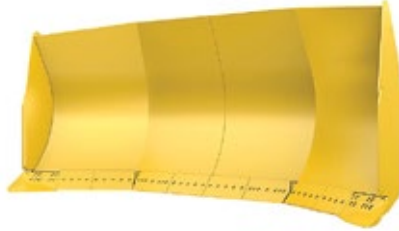

U Blade

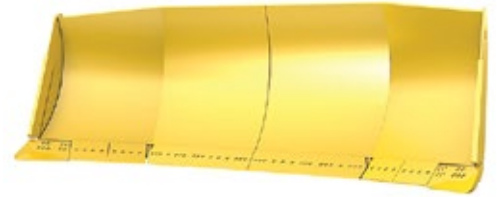

Semi U Blade



Straight Blade

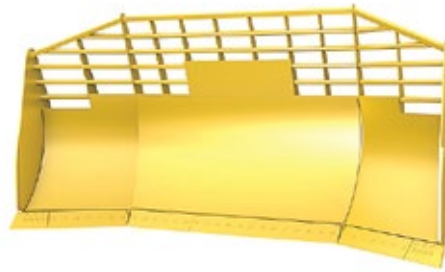

Waste Blade



1 shank ripper

3 shank ripper

Rippers

The attachments shown are for reference only; the final product may be different from the images shown.

For more options contact your nearest dealer.

Equipment specifications and images may change without notice from Rhino Equipment Group Inc.