



RWL186

WHEEL LOADERS



More power and control mean more productivity.



If you've got maximum productivity in mind, the RWL Series Loaders should be at the top of your list. But it's not just their big torque reserves that make them such impressive performers. Joystick control provide smooth, near-effortless control. Rhino hydraulics sense the load and deliver the flow needed for smooth combined functions and fast work cycles.



1. Control panel provides access to a machine info, brake and throttle pedals are conveniently positioned.
2. Guarding specially designed for waste handling operations and extra protection for the operator.
3. Reliable and durable Cummins 6CTA diesel engine, more efficient with low maintenance costs.



ENGINE

Model	Cummins / 6CTAA8.3-C or Rhino	
Emission Rating (optional)	Tier 2 (Tier 3, Tier 4)	
Cylinders	6	
Displacement L (cu. In)	8.3(506)	
Net Power kW (Hp) @ Rated rpm	179(240)@ 2,200 rpm	
Net Peak Torque Nm (lb-ft) @ Rated rpm	1,146(845)@ 1,500 rpm	
Net Torque Rise	48%	
Fuel System	Direct Injection	
Lubrication	Full-flow spin-on filter	
Aspiration	Turbocharged, charge air cooled	
Air Cleaner	Under-hood, dual element dry type, restriction indicator on filter housing for service	
Fan Drive	Hydraulic driven	
Electrical System	24 Volts with 70 Amp alternator	
Batteries (2-12 volt)	120A	

TRANSMISSION

Type	Powershift	
Torque Converter	Single-stage, Dual-phase, Quad-element torque	
Operator Interface	Steering column lever for two gears forward and one in reverse	
Shift Modes	Manual activation (Forward: 1st and 2nd; Reverse: 1st)	
Maximum Travel Speeds (with 23.5 R 25 tires)	Forward	Reverse
1st Gear km/h (mph)	12(7)	14(9)
2nd Gear km/h (mph)	38(23)	

AXLES/BRAKES

Final Drives	Heavy duty inboard-mounted planetary	
Differentials	Helical bevel gear	
Rear Axle Oscillation (with 23.5 R 25 tires)	24 degrees (12 degrees each direction)	
Service Brakes	Pneumatically assisted, hydraulically actuated, four wheels disk brake	
Parking Brake	Manually activated, drum mounted on front output shaft	

TIRES/WHEELS

	Tread Width mm (in)	Width Over Tires mm (in)
23.5 R 25 16 Ply	2,300(90.6)	2,897(114.1)

Equipment specifications and images may change without notice from Rhino Equipment Group Inc.



REFILL CAPACITIES L (gal)

Fuel Tank	350(92)
Cooling System	22(6)
Engine Oil	19(5)
Transmission Fluid	45(12)
Axle Oil (Front and Rear, each)	20(5)
Hydraulic Tank	250(66)
Brake System (Front and Rear Booster Pump, each)	1.5(0.4)

HYDRAULIC SYSTEM/STEERING

Pump (Loader and Steering)	Gear Pump, variable displacement, closed-center
Max. Rated Flow at 1,920 rpm L/min (gpm)	180(48)
System Relief Pressure (Loader and Steering) Mpa (psi)	20(2,901)
Loader Controls	Dual-multiway valve, joystick control

STEERING

Type	Articulated frame, fully hydraulic
Articulation Angle	35 degrees
Turning Radius (measured to centerline of outside tire) mm (ft)	6,400(21.0)
Hydraulic Cycle Times	Z-Bar
Raise sec.	6.0
Dump sec.	1.9
Lower sec.	3.9
Total sec.	11.8

Loader operating information is based on machine with identified linkage and standard equipment, standard tires, full fuel tank, and 79-kg (175 lb.) operator. This information is affected by changes in tires, ballast, and different attachments.

Equipment specifications and images may change without notice from Rhino Equipment Group Inc.

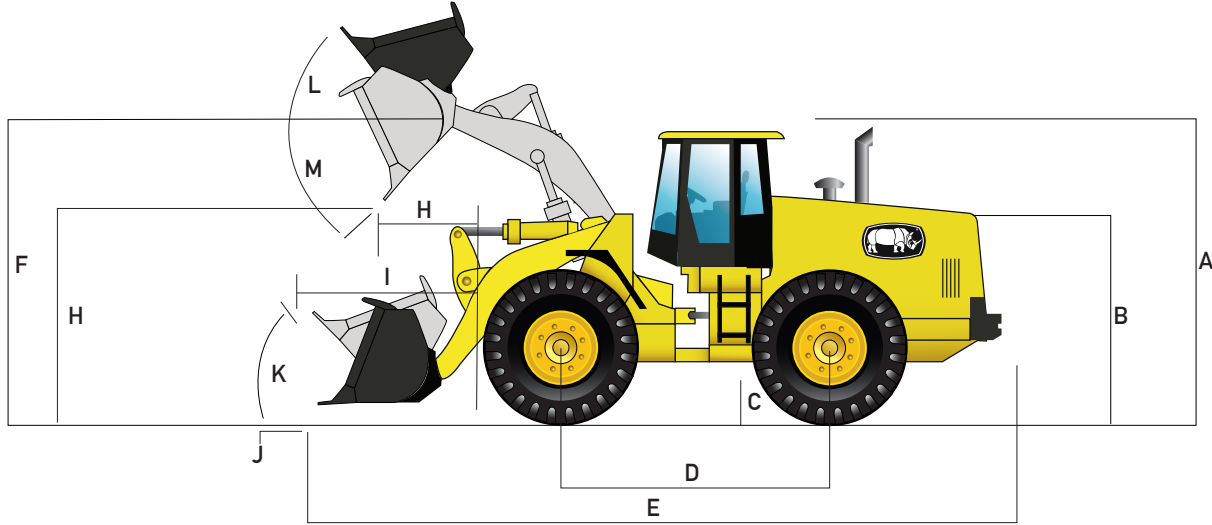

DIMENSIONS WITH BUCKET 3.5 m³ (4.6 cu. Yd) General pupose with Bolt on teeth

A Height to Top of Cab and Canopy mm (ft)	3,565(11.7)
B Hood Height mm (ft)	3,445(11.3)
C Ground Clearance mm (ft)	460(1.5)
D Wheel base mm (ft)	3,300(10.8)
E Overall Length, Bucket on Ground mm (ft)	8,280(27.2)
F Height to Hinge Pin, Fully Raised mm (ft)	4,300(14.1)
G Dump Clearance, 45 degree Full Height mm (ft)	3,028(9.9)
H Reach, 45 degree Dump, Full Height mm (ft)	1,320(4.3)
I Reach, 45 degree Dump, 2,130mm (7ft) Clearance mm (ft)	2,100(6.9)
J Max. Digging Depth mm (ft)	212(0.7)
K Max. Rollback at Ground Level	50 degrees
L Max. Rollback, Boom Fully Raised	67 degrees
M Max. Bucket Dump Angle, Fully Raised	48 degrees
Loader Clearance Circle, Bucket Carry Position mm (ft)	15,965(52.4)

SPECIFICATIONS WITH BUCKET

Capacity, Heaped m ³ (cu. Yd)	3.5(4.6)
Capacity, Struck m ³ (cu. Yd)	3.0(3.9)
Bucket Weight Kg (lb)	1,650(3,638)
Bucket Width mm (ft)	3,064(10.1)
Breakout Force Kg (lb)	18,600(41,006)
Tipping Load, Straight Kg (lb)	14,057(30,990)
Tipping Load, 35 degree Full Turn Kg (lb)	12,850(28,329)
Operating Weight Kg (lb)	18,600(41,006)

BUCKET OPTIONS

Bucket Capacities 3.0m³ - 4.5m³ (3.9 cu. Yd - 5.2 cu. Yd)

Buckets can be custom made depending on client requirements such as a bigger bucket for lighter material handling or clam buckets or among many other options.



ATTACHMENTS

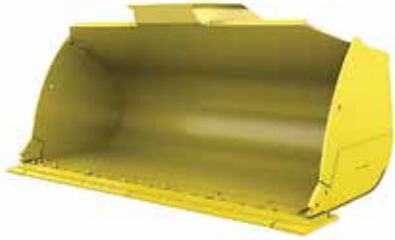

Material Handling Bucket



Waste Bucket

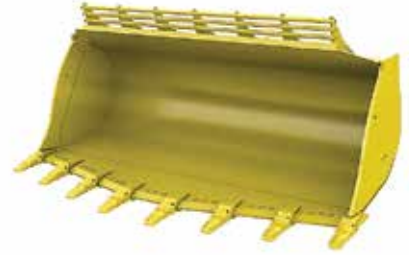

Rock Bucket



Slag Bucket



Multi-Purpose Bucket



Multi-Purpose Blades



Grapple Forks



Lumber Forks



Pallet Forks



The attachments shown are for reference only; the final product may be different from the images shown.

For more options contact your nearest dealer.

Equipment specifications and images may change without notice from Rhino Equipment Group Inc.

www.rhinoeq.com